

Fieldbus

BC (CANopen), BP (PROFIBUS DP), EH (EtherCAT),
EW (POWERLINK), EI (EtherNet/IP), EP (PROFINET RT/IRT)

Typical CANopen or PROFIBUS DP fieldbus network

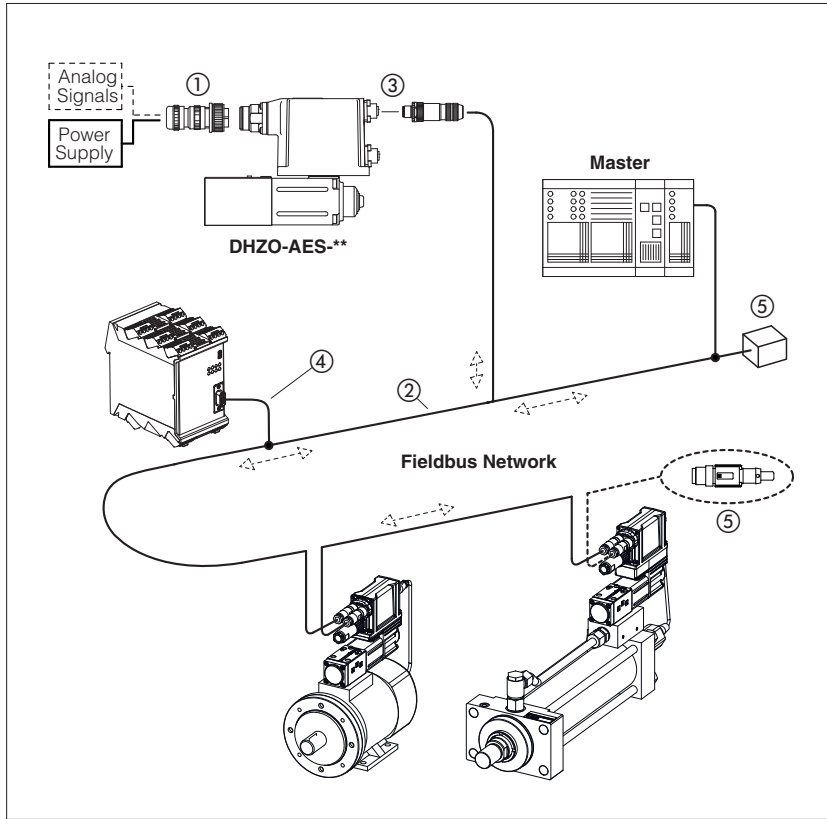

Fieldbus communication interfaces are available for digital proportional drivers and controllers, granting several plus:

- more information available for machine operation to enhance its performances
- improved accuracy and robustness of digital transmitted information
- costs reduction due to simpler and standardized wiring solutions
- costs reduction due to fast and simple installation and maintenance
- direct integration into machine's communication networks

These executions allow to operate proportional valves and pumps through fieldbus or using the analog signals on main connector ①.

Fieldbus distributed-control

Fieldbus communication allows to share all the available information of the digital drivers and controllers (reference, monitor, etc).

This distributed-control design allows to implement powerful machines functionalities for tuning, diagnostic, maintenance, etc.

Typical EtherCAT, POWERLINK, EtherNet/IP or PROFINET RT/IRT fieldbus network

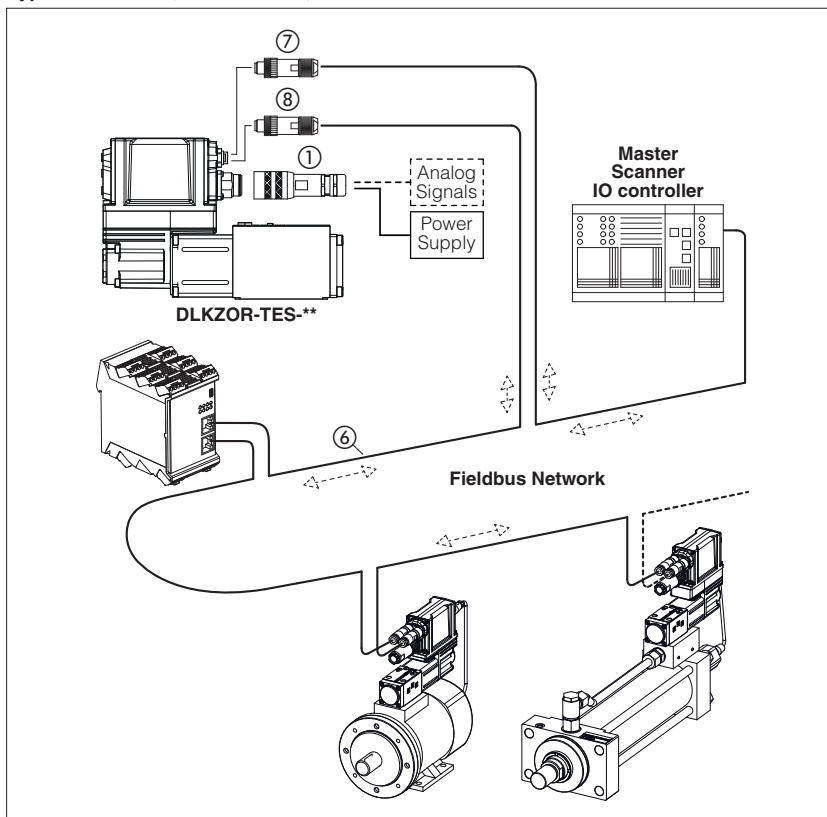

CANopen and PROFIBUS DP networks consist of a common cable (2 twisted wire, ②) for digital communication: several devices (node ③) can be connected to this main cable by means of short cable branches ④.

The two endpoints of the main cable must be terminated with specific devices (terminator, ⑤) to dissipate the communication signal's energy thus preventing interferences and degradations of fieldbus transmission.

EtherCAT, POWERLINK, EtherNet/IP and PROFINET RT/IRT networks consist in a Ethernet common cable (4 twisted wire, ⑥) for digital communication. All slave, adapter and IO device have always the double connector for signal input ⑦ and signal output ⑧.

The main Ethernet cable starting from the master, scanner and IO controller has to be connected to the slave, adapter and IO device input connector.

The slave, adapter and IO device output connector has to be connected to the next slave, adapter and IO device input connector.

1 CANopen features for digital drivers and controllers in BC execution

Physical

Serial input format	Industrial field-bus with optical insulation type CAN-Bus ISO11898
Transmission rate	Transmission rates from 10 Kbit/s to 1 Mbit/s
Max node	32 per segment without repeater; 127 per segment with repeater

Communication Protocol

Data Link Layer	DS301 V4.2.0 - based on CAN standard frame with 11-bit identifier
Device Profile	DS408 - Fluid Power Technology (EN50325-4)
Device type	Slave

Startup and configuration (as per DS301+DSP305)

Boot up process	Minimum boot-up
Node setting	LSS (Layer Setting Services) SDO E-SW-FIELDBUS and Z-SW-FULL programming software
Baudrate setting	LSS (Layer Setting Services), SDO
Baudrate	10 / 20 / 50 (default) / 125 / 250 / 500 / 1000Kbit/s

Fieldbus communication diagnostic (as per DS301)

Device Error	Emergency
Network Error	Node Guarding Heartbeat

Real-time communication (as per DS301 + DS408)

RPDO	4 mappable PDOs to the drivers: AES, BM-AES, TES, LES, RES, BM-RES, PES; TERS ex-proof, AERS ex-proof 4 mappable PDOs to the controllers: TEZ, LEZ, BM-KZ
TPDO	4 mappable PDOs from the drivers: AES, BM-AES, TES, LES, RES, BM-RES, PES; TERS ex-proof, AERS ex-proof 4 mappable PDOs from the controllers: TEZ, LEZ, BM-KZ
R(T)PDO types	Event Triggered, Remotely requested, Sync(cyclic) and Sync(acyclic)

Non real-time communication (as per DS301 + DS408)

SDO	1 SDO (1 Server + 1 Client)
-----	-----------------------------

Standard references

ISO 11898

Road Vehicles – Interchange of digital information controller area network (CAN) for High-speed communication

EN50325-4

Industrial communication subsystem based on ISO 11898 (CAN) for controller device interfaces

CiA DS301

CANopen – Application Layer and Communication Profile for Industrial Systems

CiA DR303-1

Cabling and connector pin assignment

CiA DSP305

CANopen – Layer Setting Services and Protocol

CiA DS408

CANopen – Device Profile for Proportional Hydraulic Valves v 1.5.2

Programming interface

E-SW-FIELDBUS and Z-SW-FULL software using proper cable/adaptor (see tech table **GS500**) or CANopen master device

Configuration file

EDS (Electronic Data Sheet), enclosed in programming software DVD E-SW-FIELDBUS and Z-SW-FULL

Manuals

E-MAN-S-BC and STARTUP-FIELDBUS, enclosed in programming software DVD E-SW-FIELDBUS

Z-MAN-S-BC and STARTUP-FULL, enclosed in programming software DVD Z-SW-FULL

2 PROFIBUS DP features for digital drivers and controllers in BP execution

Physical

Serial input format	Industrial field-bus with optical insulation type PROFIBUS-DP RS485 European fieldbus standard (lev.1 – EN50170-part 2)
Transmission rate	Transmission rates from 9,6 Kbit/s to 12 Mbit/s
Max node	32 per segment without repeater; 126 node with repeater

Communication Protocol

Data Link Layer	PROFIBUS DPV0 - IEC 61158 (type 3)
Device Profile	PROFIBUS-DP Profile for Fluid Power Technology
Device type	Slave

Startup and configuration

Boot up process	SAP 61 for sending parameter setting data SAP 62 for checking configuration data
Node setting	SAP 55 E-SW-FIELDBUS and Z-SW-FULL programming software
Baudrate setting	Automatic
Baudrate	9,6 / 19,2 / 45,45 / 93,75 / 187,5 / 500 / 1500 / 3000 / 6000 / 12000 Kbit/s

Fieldbus communication diagnostic

Device error	SAP 60
--------------	--------

Real-time communication

PZD	Process data area of PPO telegram by Data Exchange, default SAP: cyclic transmission of standard Profibus frame
-----	--

Standard electronics - drivers

PPO type 3 for:

AES s40, BM-AES s10, TES s40, LES s40, RES s10, BM-RES s10

PPO type 5 for:

TES s40, LES s40, PES s40 with S option

PPO type 113, 213, 230 for:

TES s40, LES s40, RES s10

PPO type 115, 214, 240 for:

TES s40, LES s40, PES s40 with S option

Standard electronics - controllers

PPO type 1, 101, 103 for:

TEZ s40, LEZ s40, BM-KZ s10

PPO type 111, 121, 123, 223, 227 for:

TEZ s40, LEZ s40, BM-KZ s10 with SP, SF, SL controls

Ex-proof electronics - drivers

PPO type 3 for:

AES s30, TES s31, LES s31, TERS s31, AERS s31

PPO type 5 for:

TES s31, LES s31

Cyclic mode	standard, sync and freeze
-------------	---------------------------

Non real-time communication

PKW	Parameter data area of PPO telegram by Data Exchange, default SAP: acyclic transmission of standard Profibus frame
-----	---

Standard references

PROFIBUS profile

PROFIBUS Profile,
Fluid Power Technology,
Edition Oct. 2001

VDMA profile

Fluid Power Technology,
Proportional Valves and
Hydrostatic Transmissions, ver 1.1

Programming interface

E-SW-FIELDBUS and Z-SW-FULL software using proper cable/adapter (see tech table **GS500**) or PROFIBUS DP master device

Configuration file

GSD (General Station Description) enclosed in programming software DVD E-SW-FIELDBUS and Z-SW-FULL

Manuals

E-MAN-S-BP and STARTUP-FIELDBUS, enclosed in programming software DVD E-SW-FIELDBUS

Z-MAN-S-BP and STARTUP-FULL, enclosed in programming software DVD Z-SW-FULL

3 EtherCAT features for digital drivers and controllers in EH execution

Physical

Serial input format	Industrial fieldbus type Fast Ethernet galvanically insulated IEC 61158-2
Transmission rate	2 x 100 Mbit/s (Fast Ethernet, Full-Duplex)
Max node	65535 slaves
Ethernet Standard	ISO/IEC 8802-3 frame format
EtherType	0x88A4 according to IEEE 802.3
Cable length	0,2 - 100m (between two slave devices)
Cable type	CAT5 (4 wire twisted pair) according with T568B
Network topology	Line, tree and star
Termination	Device internally

Communication Protocol

Data Link Layer	EtherCAT use Standard Ethernet Frames: ISO/IEC 8802-3 + IEC 61784-2
Device Profile	CANopen over EtherCAT (CoE) DS408 - Fluid Power Technology EN 50325-4
Device type	Slave
Supported protocol	CANopen SDO Mailbox-Interface "CoE" Network Management PDO PDO Watchdog Cycle time min 1 msec

Startup and configuration (as per DS301+DSP305)

Node setting	Automatic position addressing Device node addressing
Baudrate	100 Mbit/s (Automatic)

Fieldbus communication diagnostic (as per DS301)

Device Error	Emergency
--------------	-----------

Real-time communication (as per DS301 + DS408)

RPDO	4 PDOs messages to the driver (up to 32 byte for each PDO)
TPDO	4 PDOs messages from the driver (up to 32 byte for each PDO)
R(T)PDO types	Remotely requested

Non real-time communication (as per DS301 + DS408)

SDO	1 SDO (1 Server + 1 Client)
-----	-----------------------------

Standard references

ISO 11898

Road Vehicles – Interchange of digital information controller area network (CAN) for High-speed communication

EN 50325-4

Industrial communication subsystem based on ISO 11898 (CAN) for controller device interfaces

CiA DS301

CANopen – Application Layer and Communication Profile for Industrial Systems

CiA DSP305

CANopen – Layer Setting Services and Protocol

CiA DS408

CANopen – Device Profile for Proportional Hydraulic Valves v 1.5.1

IEC 61076-2-101

Connectors for electronic equipment
- Product Requirements -
Part 2-101: Circular connectors
- Detail specification for M12 connectors with screw-locking

IEC 61158-2

Industrial communication networks
- Fieldbus specification -
Part 2: Physical layer specification and service definition

IEC 61784-2

Industrial communication networks
- Profiles -
Part 2: Additional fieldbus profiles for real-time networks based on ISO/IEC 8802-3

Programming interface

E-SW-FIELDBUS and Z-SW-FULL software using proper cable/adapter (see tech table **GS500**) or EtherCAT master device

Configuration file

XML (Extensible Markup Language) enclosed in programming software DVD E-SW-FIELDBUS and Z-SW-FULL

Manuals

E-MAN-S-EH and STARTUP-FIELDBUS, enclosed in programming software DVD E-SW-FIELDBUS
Z-MAN-S-EH and STARTUP-FULL, enclosed in programming software DVD Z-SW-FULL

4 POWERLINK features for digital drivers and controllers in EW execution

Physical

Serial input format	Industrial fieldbus type Fast Ethernet galvanically insulated IEC 61158-2
Transmission rate	2 x 100 Mbit/s (Fast Ethernet, Half-Duplex)
Max node	239 slaves
Ethernet Standard	ISO/IEC 8802-3 frame format
EtherType	0x88AB according to IEEE 802.3
Integrated Hub	
Cable length	0,2 - 100m (between two slave devices)
Cable type	CAT5 (4 wire twisted pair) according with T568B
Network topology	Line, tree, star, daisy chain, ring structure or any combination of these topologies
Ethernet Hub	Integrated with 2 ports: - one led for Link/Activity indicator (on each port) - one bicolor led Status/Error indicator

Communication Protocol

Data Link Layer	POWERLINK use Standard Ethernet Frames: ISO/IEC 8802-3 + IEC 61784-2
Comm. Profile	EPSP DS 301 v1.2
Device Profile	CANopen over Ethernet based on DS408 - Fluid Power Technology
Device type	Slave - supported features: - Ethernet POWERLINK v2.0 - Ring Redundancy - Support PollResponse Chaining - Support Multiplexing - Cycle time min 200 µsec - SDO Multiple Parameter Read/Write

Startup and configuration (as per EPSP DS301 + EPSP DS 302-A/B/C/D/E)

Node setting	E-SW-FIELDBUS and Z-SW-FULL programming software
Baudrate	100 Mbit/s (Automatic)

Fieldbus communication diagnostic

Custom parameters mappable on TPDO for emergency diagnosis

Real-time communication (as per EPSP DS301 + DS408)

RPDO	1 PDO message to the driver (max number of of mapping parameters is Device specific)
TPDO	1 PDO message from the driver (max number of of mapping parameters is Device specific)

Standard references

EPSP DS301
Ethernet POWERLINK
Communication Profile Specification v 1.2

EPSP DS302-A/B/C/D/E
Ethernet POWERLINK
Part A: High Availability v1.1
Part B: Multiple ASnd v1.0
Part C: PollResponse Chaining v1.0
Part D: Multiple PReq/Pres v1.0
Part E: Dynamic Node Allocation v1.0

EPSP DS311
Ethernet POWERLINK
XML Device Description v 1.0

CiA DS408
CANopen – Device Profile for Proportional Hydraulic Valves v 1.5.1

IEC 61076-2-101
Connectors for electronic equipment
- Product Requirements -
Part 2-101: Circular connectors
- Detail specification for M12 connectors with screw-locking

IEC 61158-2
Industrial communication networks
- Fieldbus specification -
Part 2: Physical layer specification and service definition

IEC 61784-2
Industrial communication networks
- Profiles -
Part 2: Additional fieldbus profiles for real-time networks based on ISO/IEC 8802-3

IEC 61784-3
Industrial communication networks
- Profiles -
Part 3: Functional safety fieldbuses -
General rules and profile definitions

IEC 61158-300/400/500/600
Industrial communication networks
- Fieldbus specifications -
Part 300: Data Link Layer service definition
Part 400: Data Link Layer protocol specification
Part 500: Application Layer service definition
Part 600: Application Layer protocol specification

ISO 15745-1
Industrial automation systems and integration - Open systems application integration framework -
Part 1: Generic reference description

Programming interface

E-SW-FIELDBUS and Z-SW-FULL software using proper cable/adapter (see tech table **GS500**) or POWERLINK master device

Configuration file

XDD (XML Device Description) enclosed in programming software DVD E-SW-FIELDBUS and Z-SW-FULL

Manuals

E-MAN-S-EW and STARTUP-FIELDBUS, enclosed in programming software DVD E-SW-FIELDBUS
Z-MAN-S-EW and STARTUP-FULL, enclosed in programming software DVD Z-SW-FULL

Physical

Ethernet Standard	ISO/IEC 8802-3 frame format
EtherType	0x08E1 according to IEEE 802.3
Transmission rate	10/100 Mbit Full/Half-Duplex
Integrated	2-port switch
Cable length	max 100m
Cable type	CAT5 (4 wire twisted pair) according with T568B
Network topology	Device Level Ring (DLR), linear, star structure
Ethernet switch	integrated with two ports
Led indicator	2 led for Link/Activity indicator (on each port) and 1 bicolor led for Status/Error indicator

Communication Protocol

ODVA CIP Object Model

ODVA CIP Object library for Generic Device Profile

- Identity Object (0x01)
- Message Router Object (0x02)
- Assembly Object (0x04)
- Connection Manager Object (0x06)
- Parameter Object (0x0F)
- DLR Object (0x47)
- QoS Object (0x48h)
- Port Object (0xF4)
- TCP/IP Object (0xF5)
- Ethernet Link Object (0xF6)

Valve parameters accessible via Vendor Specific Object 0xA2

IP address setting (range 0.0.0.0 - 255.255.255.255):

- TCP/IP Object (0xF5)
- DHCP
- Auxiliary USB communication + Atos Software

I/O Adapter and Explicit Message Server device type

Cyclic data transmission via Implicit Messages (transport class 1)

- Minimum RPI for Implicit Messages 1ms
- Total number of supported class 1 connections: 4
- Up to 5 parameters and 20 bytes for each connection
- Trigger types: Cyclic CoS

Acyclic data transmission via Connected and Unconnected Explicit Messages (transport class 3)

- Minimum RPI for Explicit Messages 100ms
- No. of simultaneous Class 3 connections: 6

Standard references**IEC 61918**

Industrial communication networks
- Installation of communication networks
in industrial premises

IEC 61076-2-101

Connectors for electronic equipment
- Product Requirements -
Part 2-101: Circular connectors
- Detail specification for M12 connectors
with screw-locking

IEC 61158-1

Industrial communication networks
- Fieldbus specification -
Part 1: Overview and guidance for the
IEC 61158 and IEC 61784 series

IEC 61158-2

Industrial communication networks
- Fieldbus specification -
Part 2: Physical layer specification and
service definition

IEC 61784-1

Industrial communication networks
- Profiles -
Part 1: Fieldbus profile

IEC 61784-2

Industrial communication networks
- Profiles -
Part 2: Additional fieldbus profiles for real-
time networks based on ISO/IEC 8802-3

IEC 61784-3

Industrial communication networks
- Profiles -
Part 3: Functional safety fieldbuses -
General rules and profile definitions

IEC 61784-5-2

Industrial communication networks
- Profiles -
Part 5-2: Installation of fieldbuses -
Installation profiles for CPF 2

ISO 15745-4

Industrial automation systems and
integration - Open systems application
integration framework -
Part 4: Reference description for Ethernet-
based control systems

Programming interface

E-SW-FIELDBUS and Z-SW-FULL software using proper cable/adaptor (see tech table **GS500**) or EtherNet/IP scanner device

Configuration file

EDS (Electronic Data Sheet) enclosed in programming software DVD E-SW-FIELDBUS and Z-SW-FULL

Manuals

E-MAN-S-EI and STARTUP-FIELDBUS, enclosed in programming software DVD E-SW-FIELDBUS

Z-MAN-S-EI and STARTUP-FULL, enclosed in programming software DVD Z-SW-FULL

6 PROFINET RT/IRT features for digital drivers and controllers in EP execution

Physical

Ethernet Standard	ISO/IEC 8802-3 frame format
EtherType	0x8892 according to IEEE 802.3
Transmission rate	100 Mbit Full-Duplex
Integrated	2-port switch
Cable length	max 100m
Cable type	CAT5 (4 wire twisted pair) according with T568B
Network topology	line, star, tree and ring structure
Ethernet switch	integrated with two ports
Led indicator	2 led for Link/Activity indicator (on each port) and 1 bicolor led for Status/Error indicator

Communication Protocol

Data Link Layer	PROFINET use Standard Ethernet Frames: ISO/IEC 8802-3 + IEC 61784-2
Device type	IO device - supported features: - complies with PROFINET IO conformance Class A, B, C - Acyclic parameter Channel - Real Time (RT) and Isochronous Real Time (IRT) communication - Up to 8 input/output parameters for real time data exchange - PROFINET specific diagnostic support - Media Redundancy Protocol (MRP) - DCP Discovery and Configuration Protocol supported - Identification & Maintenance (I&M) - Cycle time min: 1 msec [RT] , 250 µsec [IRT]

Startup and configuration

Address setting	IP Address and Station Name are assigned automatically by IO controller (e.g. Discovery and Configuration Protocol)
Baudrate	100 Mbit/s (Automatic)

Fieldbus communication diagnostic

Custom parameters mappable on real time communication for emergency diagnosis

Real-time communication

Modular config	up to 5 input parameters for real time data exchange up to 5 output parameters for real time data exchange
----------------	---

Standard references

IEC 61918
Industrial communication networks
- Installation of communication networks in industrial premises

IEC 61076-2-101
Connectors for electronic equipment
- Product Requirements -
Part 2-101: Circular connectors
- Detail specification for M12 connectors with screw-locking

IEC 61158-1
Industrial communication networks
- Fieldbus specification -
Part 1: Overview and guidance for the IEC 61158 and IEC 61784 series

IEC 61158-2
Industrial communication networks
- Fieldbus specification -
Part 2: Physical layer specification and service definition

IEC 61158-5-10
Industrial communication networks
- Fieldbus specification -
Part 5-10: Application layer service definition – Type 10 elements

IEC 61784-1
Industrial communication networks
- Profiles -
Part 1: Fieldbus profile

IEC 61784-2
Industrial communication networks
- Profiles -
Part 2: Additional fieldbus profiles for real-time networks based on ISO/IEC 8802-3

IEC 61784-5-3
Industrial communication networks
- Profiles -
Part 5-3: Installation of fieldbuses -
Installation profiles for CPF 3

Programming interface

E-SW-FIELDBUS and Z-SW-FULL software using proper cable/adapter (see tech table **GS500**) or PROFINET controller.

Configuration file

GSDML (Electronic Data Sheet) enclosed in programming software DVD E-SW-FIELDBUS and Z-SW-FULL

Manuals

E-MAN-S-EP and STARTUP-FIELDBUS, enclosed in programming software DVD E-SW-FIELDBUS
Z-MAN-S-EP and STARTUP-FULL, enclosed in programming software DVD Z-SW-FULL