

**Proportional Electro-Hydraulic Relieving and Reducing Valves**

This valve is derived by combining a small, high-performance 1/8 proportional electro-hydraulic pilot relief valve with a relieving and reducing valve.

With this valve, it is possible to regulate the system pressure in proportion to the input current.

Incorporating a relief mechanism, this valve provides a good response speed and the pressure decreases even if the load is large. Note that this valve is used in conjunction with the applicable power amplifier.

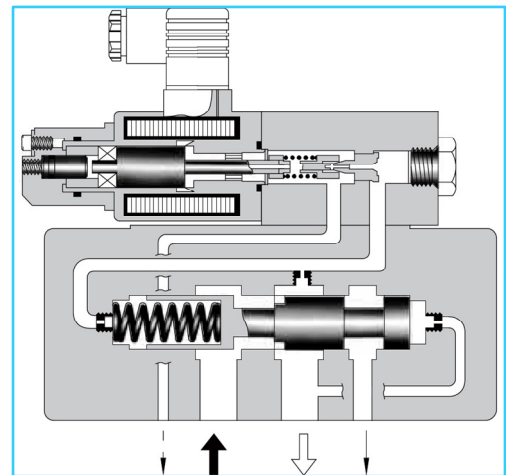
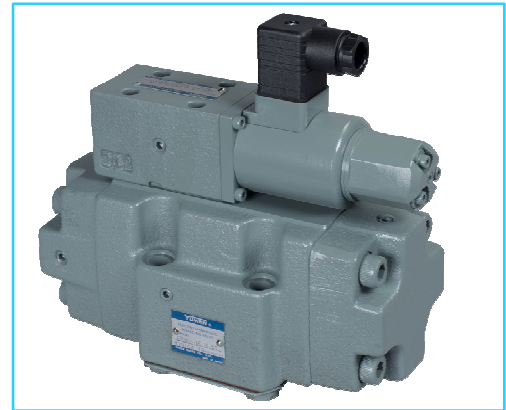

Graphic Symbol

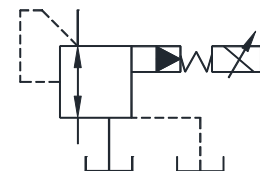

**Specifications**

Model Numbers		ERBG-06	ERBG-10
Description			
Max. Operating Pres.	Kgf/cm <sup>2</sup>	250	
Max. Flow	L/min.	100	250
Max. Relieving Flow	L/min.	35	15
Secondary Pres. Adj. Range	Kgf/cm <sup>2</sup>	Refer to Model Number Designation	
Rated Current	mA	<b>B</b> : 800 <b>C</b> : 800 <b>H</b> : 950	
Coil resistance	Ω	10	
Hysteresis		3% or less	
Repeatability		1% or less	
Mass	Kg.	12	13.5

\* The Values shown are those obtained where the differential pressure between the secondary pressure port and tank port is 140 Kgf/cm<sup>2</sup>.

**Model Number Designation**

F-	ERB	G	-06	-C	-51
Special Seals	Series No.	Type of Mounting	Valve Size	Secondary Pres. Adj. Range Kgf/cm <sup>2</sup>	Design No.
<b>F:</b> Special Seals for Phosphate Ester Type fluid (Omit if not required)	<b>ERB:</b> Proportional Electro-Hydraulic Relieving and Reducing Valve	<b>G:</b> Sub Plate Mounting	06	<b>B</b> : 8 ~ 70 <b>C</b> : 12 ~ 140 <b>H</b> : 15 ~ 210	51
			10	<b>B</b> : 9 ~ 70 <b>C</b> : 12 ~ 140 <b>H</b> : 15 ~ 210	

**Attachment**

**Mounting Bolts**

Valve Model Numbers	Socket Head Cap Screw	Qty.	Bolt Kit Model Number
ERBG-06	M10 x 70 Lg.	4	BKERBG-06-51
ERBG-10	M10 x 70 Lg.	6	BKERBG-10-51

## ■ Applicable Power Amplifier

For stable performance, it is recommended that Yuken's applicable power amplifiers be used. (For details see page no. 691)

Model Number:

- AME-D-10-※-20
- AME-D2-1010-11
- SK1022-※-※-11
- SK1015-11 (For DC Power Supply)
- AMN-D-10 (For DC Power Supply)

## ■ Sub-Plate

Valve Model Numbers	Sub-Plate Model Numbers	Thread Size	Mass Kg.
ERBG-06	ERBGM-06-2080	3/4 BSP.F	3.0
ERBG-10	ERBGM-10-1080	1-1/4 BSP.F	6.5

- Sub-plates are available. Specify the sub-plate model from the table above. When sub-plate are not used, the mounting surface should have a good machined finish.

## ■ Instructions

- **Primary Pressure Required for Preselected Pressure**  
The Primary pressure must be 10 Kgf/cm<sup>2</sup> higher than the preselected pressure
- **Drain Back Pressure**  
Check that the drain back pressure does not exceed 2 Kgf/cm<sup>2</sup>
- **Trapped Oil Volume**  
The recommended secondary side trapped oil volume is about 20 liters. Note that the trapped oil volume must not be lower than 1.4 liters.

• ERBG-06-~~※~~-51

DIMENSIONS IN MILLIMETRES

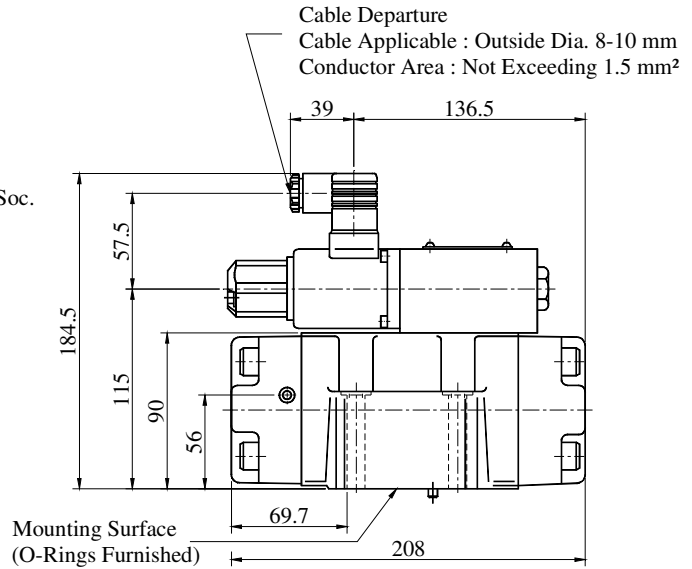
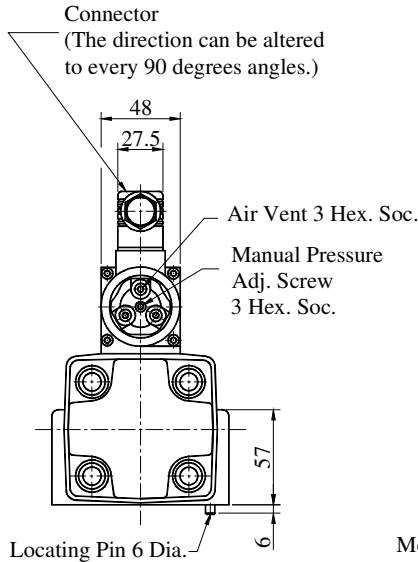
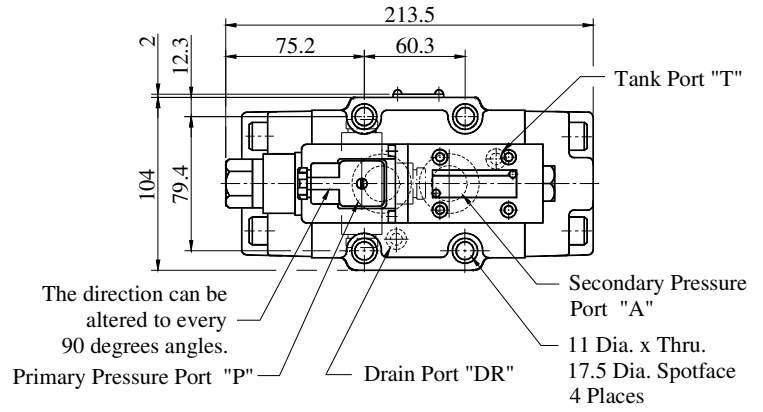

• ERBG-10-~~※~~-51

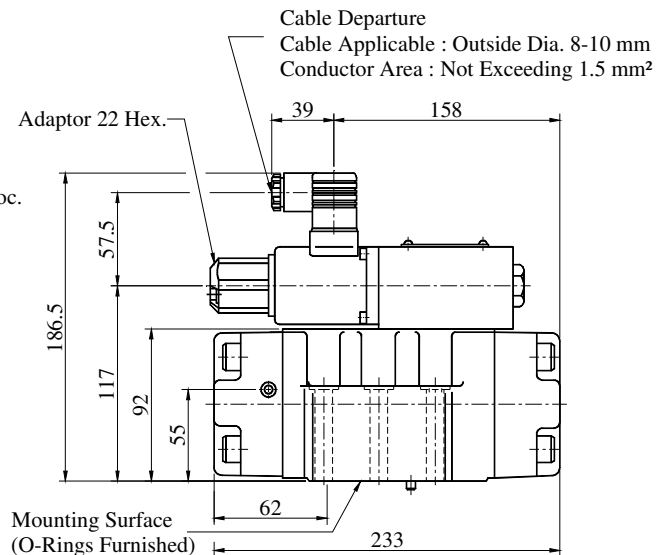
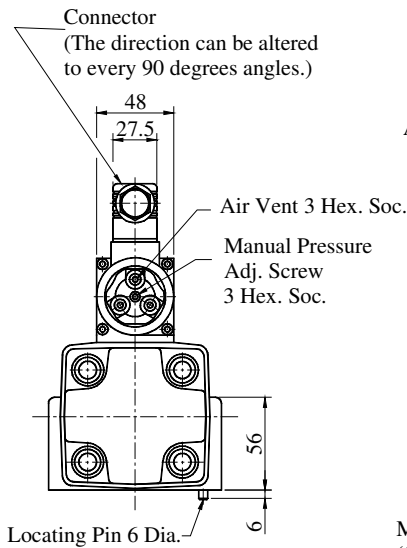
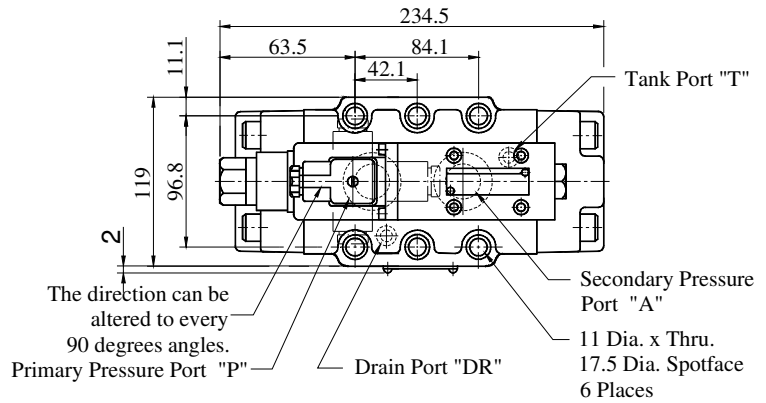

E Series

Proportional Electro-Hydraulic Reducing and Relieving Valves

Sub-Plate

• ERBGM-06-2080

M10 Thd. x 20 Deep  
4 Places

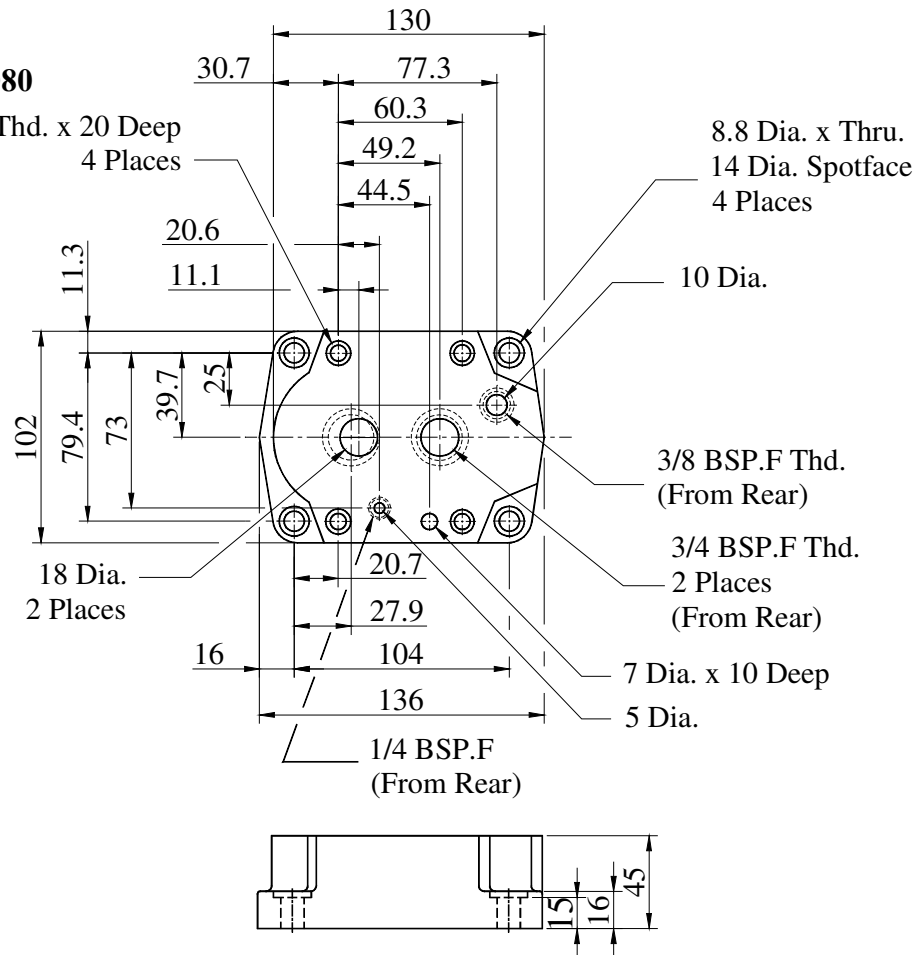

• ERBGM-10-1080

M10 Thd. x 20 Deep  
6 Places

11 Dia. x Thru  
17.5 Dia. Spotface  
4 Places

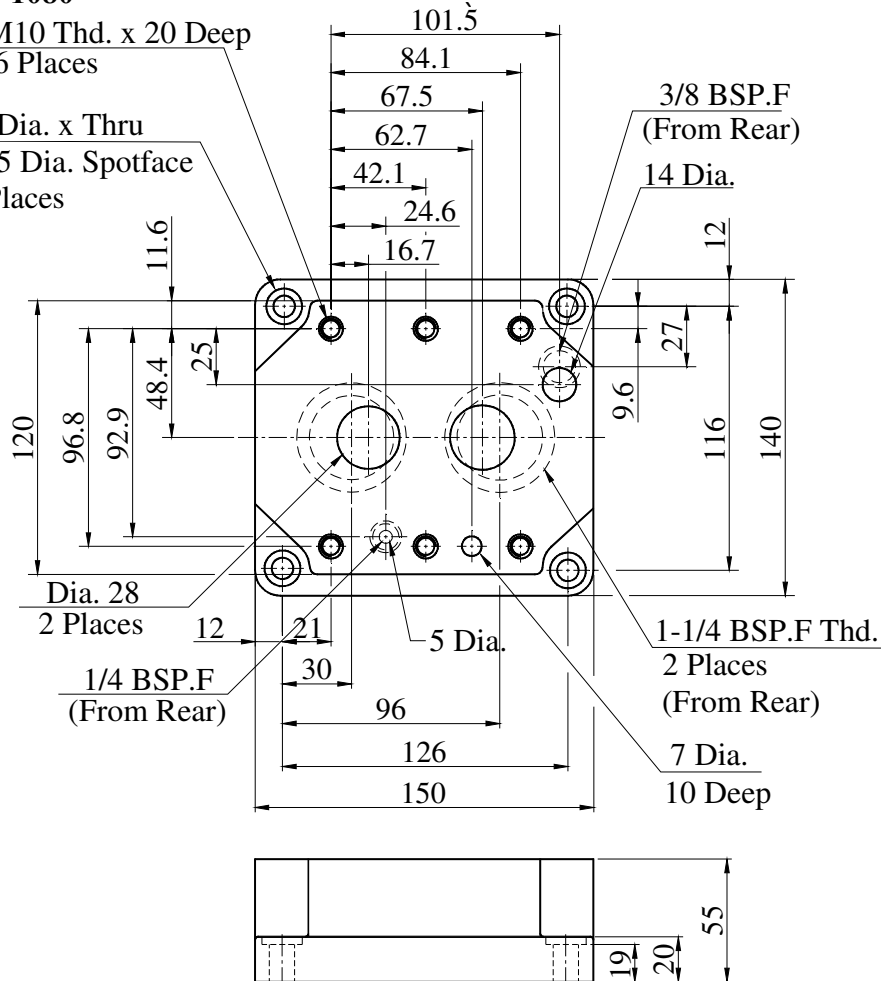

E Series

**Step Response (Example)**

The following step response characteristics are taken when the trapped oil volume is 20 liters. The step response varies by trapped oil volume.

Primary Pressure : 250 Kgf/cm<sup>2</sup>  
 Trapped Oil Volume : 20 L  
 Viscosity : 30 cSt

**ERBG-06-B**

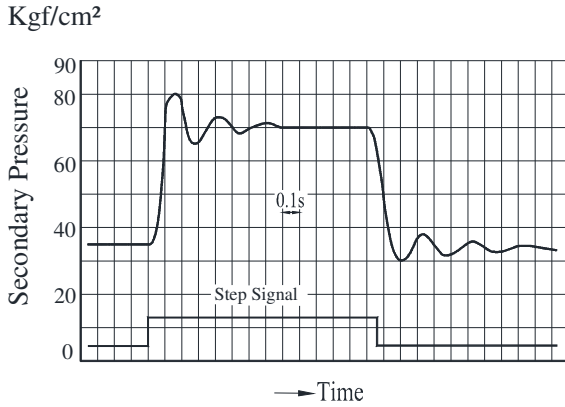

**ERBG-10-B**

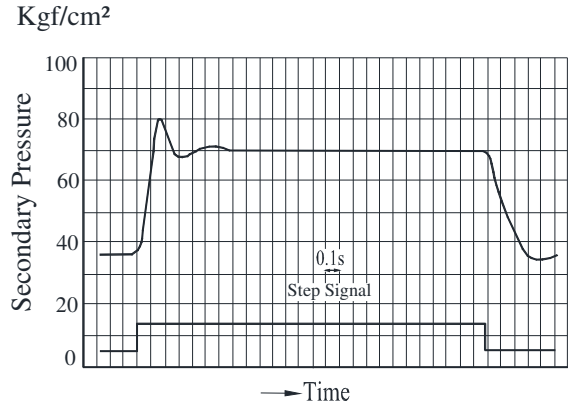

**ERBG-06-C**

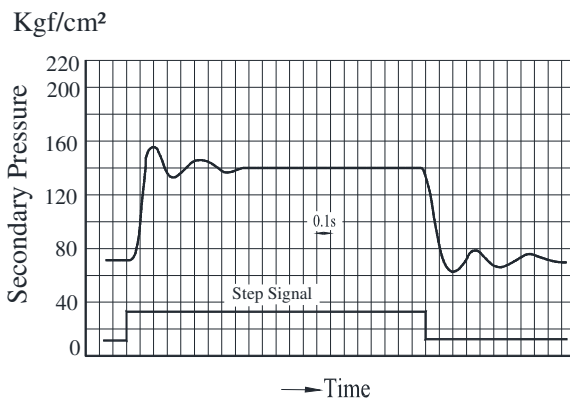

**ERBG-10-C**

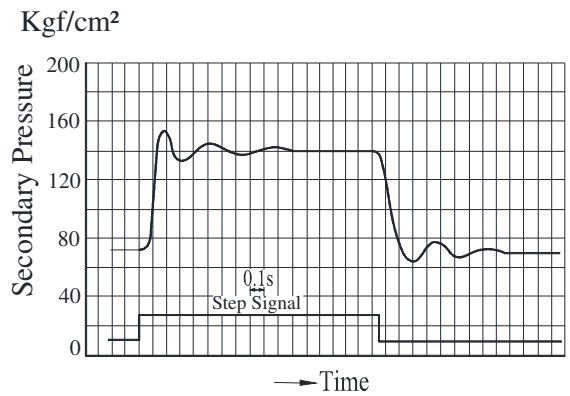

**ERBG-06-H**

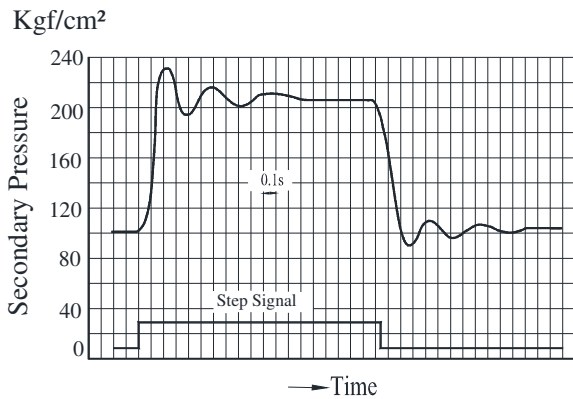

**ERBG-10-H**

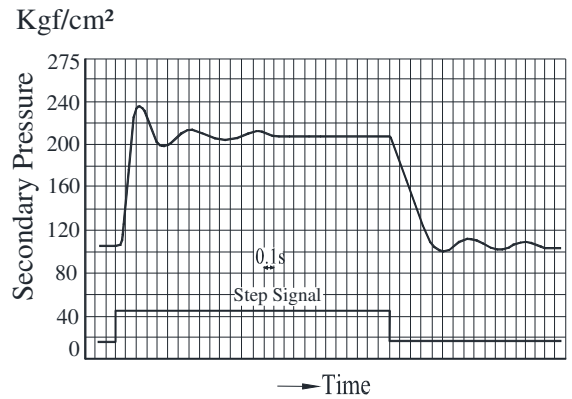

**Input Current vs. Secondary Pressure**

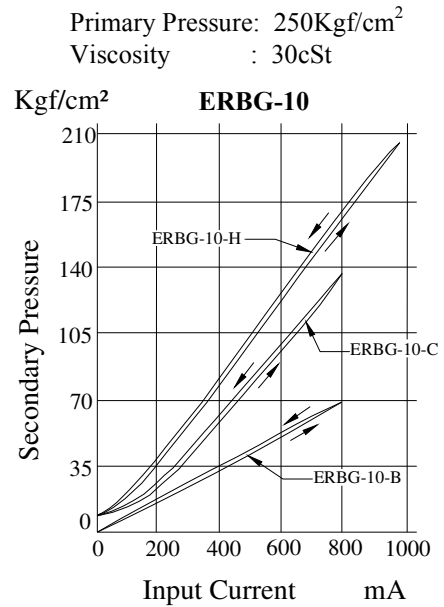
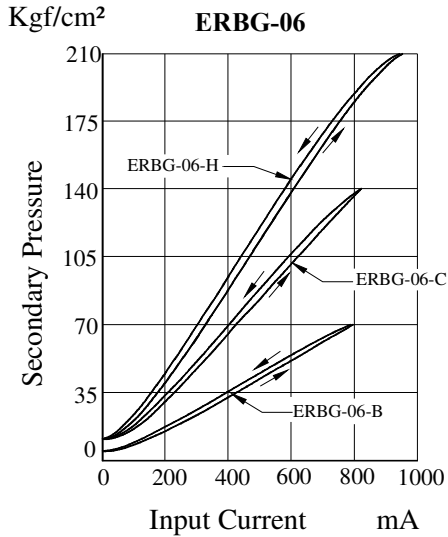

**Frequency Response**

Primary Pressure : 250 Kgf/cm<sup>2</sup>  
Trapped Oil Volume : 20 L  
Viscosity : 30 cSt

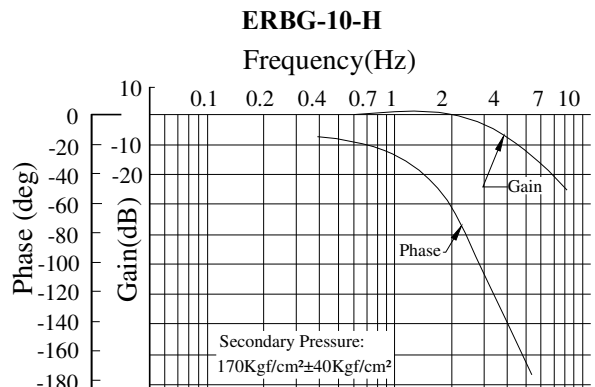
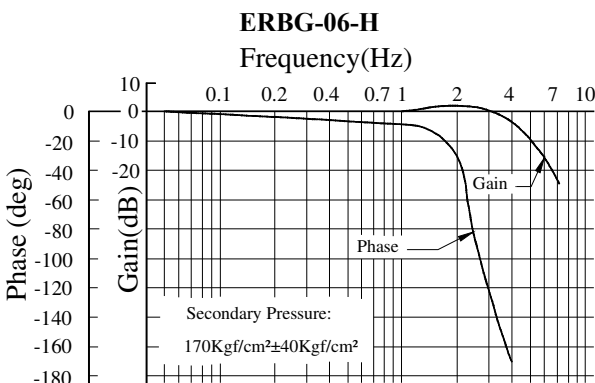
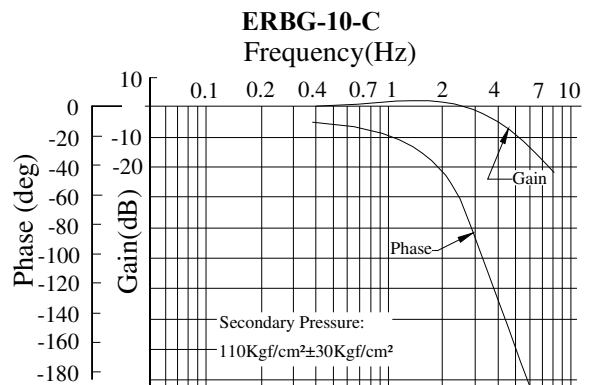
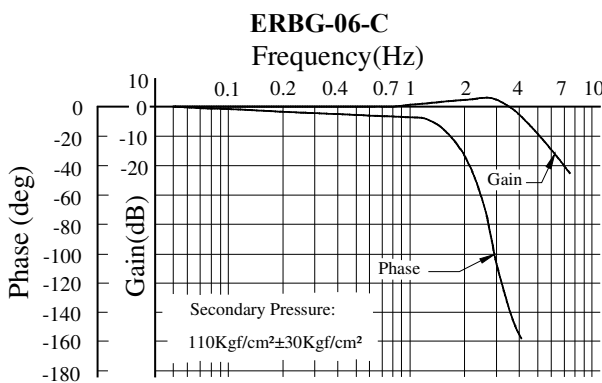
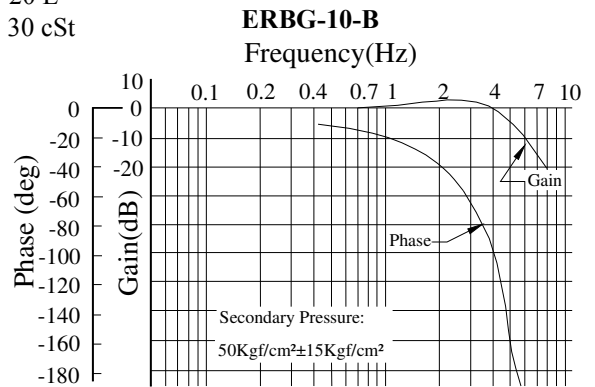
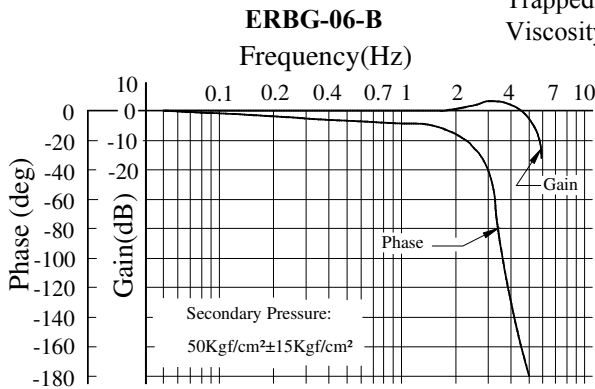

**Flow Rate vs. Secondary Pressure**

Viscosity: 30 cSt

**ERBG-06-B**

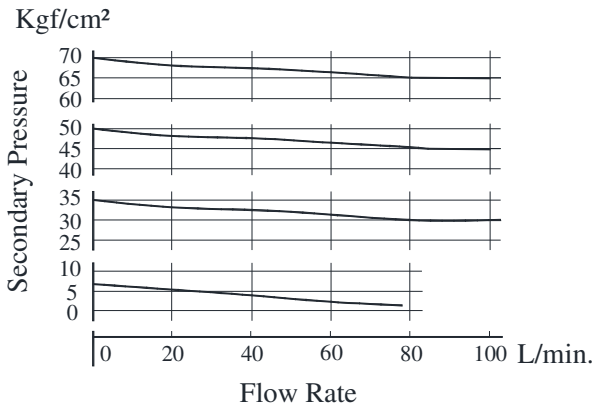

**ERBG-10-B**

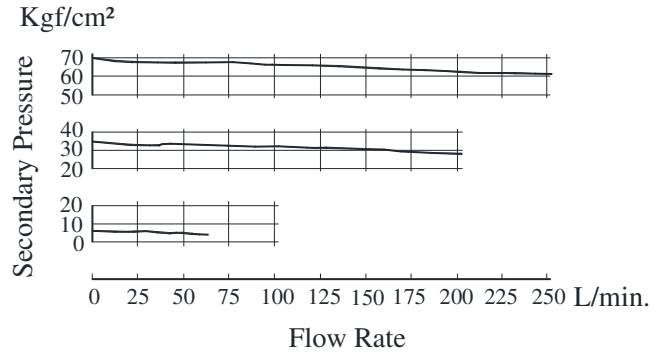

**ERBG-06-C**

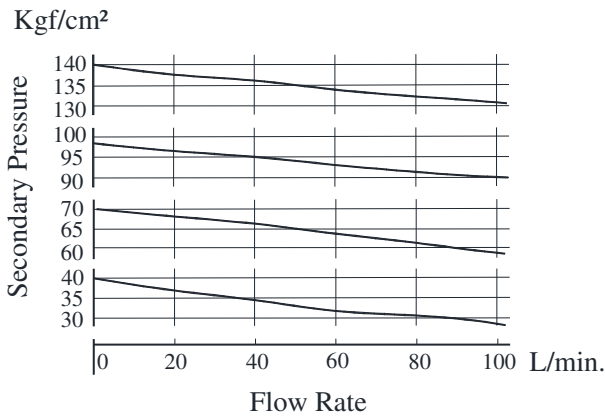

**ERBG-10-C**

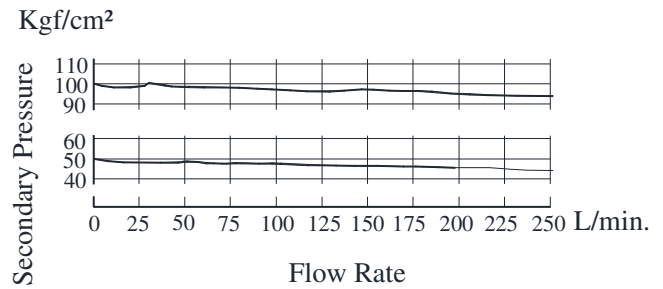

**ERBG-06-H**

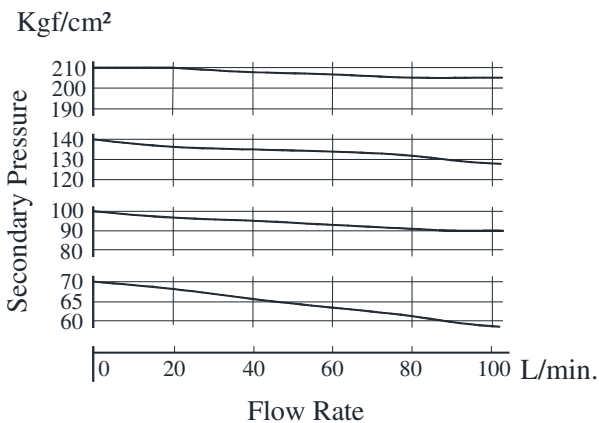

**ERBG-10-H**

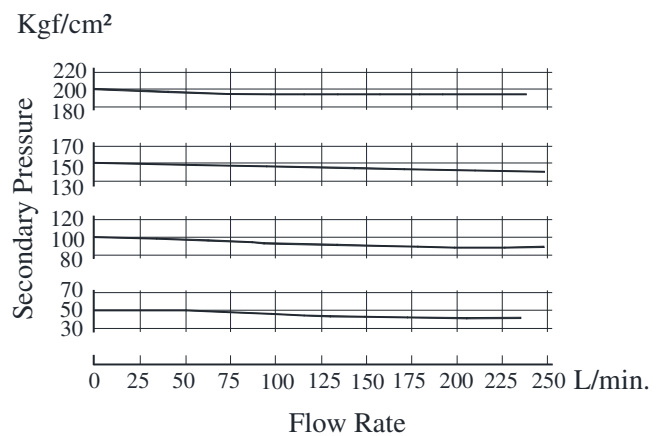

**Viscosity vs. Secondary Pressure**

Oil: ISO VG 32

**ERBG-06-B**

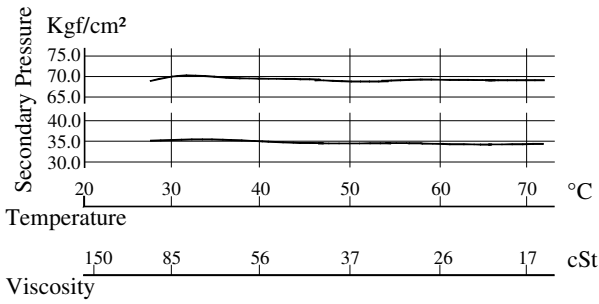

**ERBG-10-B**

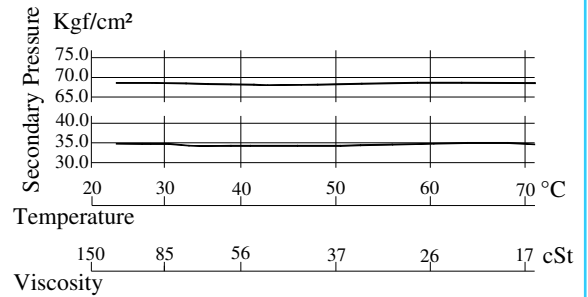

**ERBG-06-C**

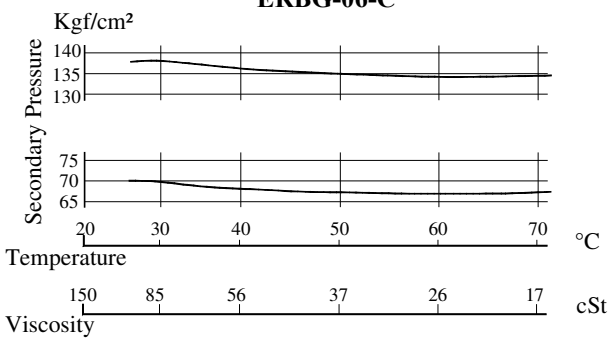

**ERBG-10-C**

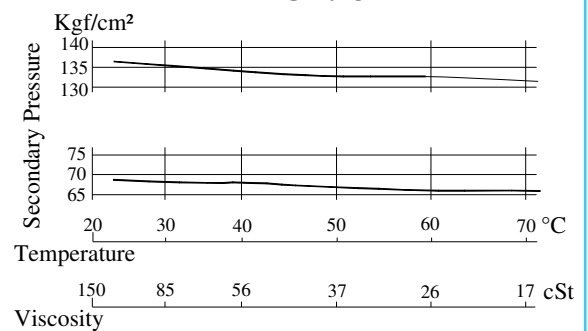

**ERBG-06-H**

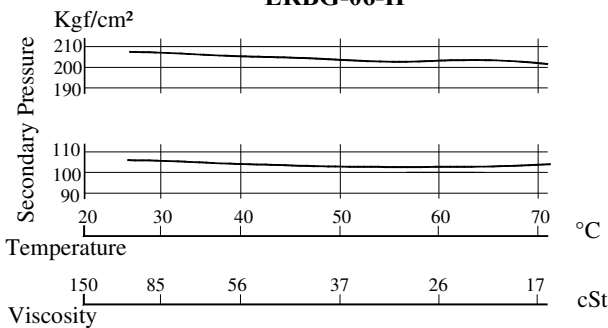

**ERBG-10-H**

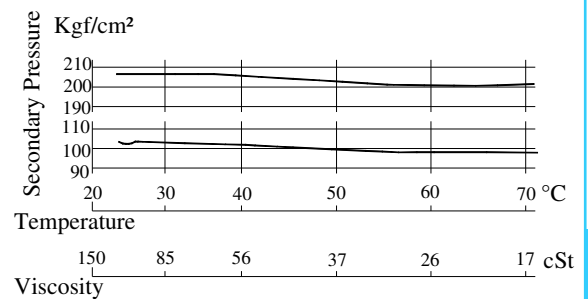

**Spare Parts List**

**List of Seals**

Sl. No.	Name of Parts	Part Numbers		Qty.
		ERBG-06	ERBG-10	
1	O-Ring	SO-NB-G30	SO-NB-P36	2
2	O-Ring	SO-NB-P28	SO-NB-P32	2
3	O-Ring	SO-NB-P14	SO-NB-P18	1
4	O-Ring	SO-NB-P9	SO-NB-P9	3

Note: When Ordering the seals, please specify the seal kit numbers KS-ERBG-06-51

**List of Seals Kits**

Valve Model Numbers	Seal Kit Numbers
ERBG-06	KS-ERBG-06-51
ERBG-10	KS-ERBG-10-51

**Pilot Valves**

Sl. No.	Valve Model Numbers	Pilot Valve Model Numbers
1	ERBG-06-B-51	EDG-01-B-PNTN-5101
2	ERBG-06-C-51	EDG-01-C-PNTN-5101
3	ERBG-06-H-51	EDG-01-H-PNTN-5101
4	ERBG-10-B-51	EDG-01-B-PNTN-5101
5	ERBG-10-C-51	EDG-01-C-PNTN-5101
6	ERBG-10-H-51	EDG-01-H-PNTN-5101